

# Flow valve

## Throttle check valve

$Q_{\max} = 80 \text{ l/min}$ ,  $p_{\max} = 350 \text{ bar}$   
direct acting, spool type, mechanically adjustable  
Type series: MDR2-6F-...A

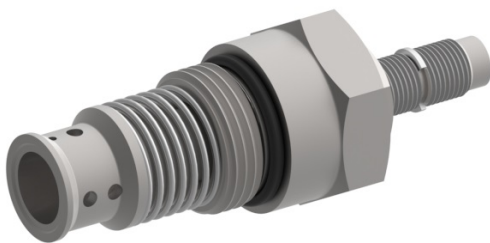

- Screw-in cartridge valve
- For cavity DF
- All external parts with zinc-nickel plating according to DIN EN ISO 19598
- Same cavity for NG6 and NG10
- Self-locking adjustment spindle with lock nut
- Fine opening in the lower volume range
- Self-cleaning throttle point

### Description

Series MDR2-... throttle check valves are size 6 screw-in units with an M20 x 1.5 mounting thread. They are designed as semi-cartridges and have an integral bypass check valve. The flow rate in direction 1 to 2 can be adjusted using the adjusting screw. In flow direction 2 to 1, the throttle function is bypassed because the flow passes through the check valve. The valve design ensures automatic self-cleaning during

reverse flow. All external parts of the screw-in valve are zinc-nickel plated and are thus suitable for use in the harshest operating environments. These 2-way flow control cartridges are used in mobile and industrial applications. If you intend to manufacture your own cavities, please refer to the section "Related data sheets".

### Symbol

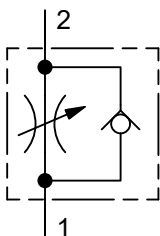

## Technical data

General characteristics	Description, value, unit
Function group	Flow valve
Function	Throttle check valve
Design	Screw-in cartridge valve
Controls	mechanically adjustable
Characteristic	direct acting, spool type
Construction size	NG 6
Thread size	M20×1,5
Mounting attitude	unrestricted
Weight	0.18 kg
Cavity acc. factory standard	For cavity DF
Tightening torque steel	50 Nm
Tightening torque aluminium	50 Nm
Tightening torque tolerance	± 10 %
Minimum ambient temperature	- 30 °C
Maximum ambient temperature	+ 80 °C
Surface protection	All external parts with zinc-nickel plating according to DIN EN ISO 19598
Sealing material	see ordering code
Seal kit order number	NBR: DS-546-N / FKM: DS-546-V

Hydraulic characteristics	Description, value, unit
Maximum operating pressure	350 bar
Maximum flow rate	80 l/min
Restriction of the flow rate	NG 6 = 80 l/min
Flow direction	see symbol
Hydraulic fluid	mineral-based or synthetics with lubricating properties. HL and HLP mineral oil according to DIN 51 524; other fluids on request!
Minimum fluid temperature	- 30 °C
Maximum fluid temperature	+ 80 °C
Viscosity range	10 ... 500 mm <sup>2</sup> /s (cSt)
Recommended viscosity range	15 ... 250 mm <sup>2</sup> /s (cSt)
Minimum fluid cleanliness (cleanliness class according to ISO 4406:1999)	class 20/18/15
Definition of cracking pressure for check valve	0.1 bar or 0.7

**Performance graphs**

measured with oil viscosity 33.0 mm<sup>2</sup>/s (cSt)

$p = f(Q)$  Pressure-flow rate

Adjustment, normal opening

Measured via check valve

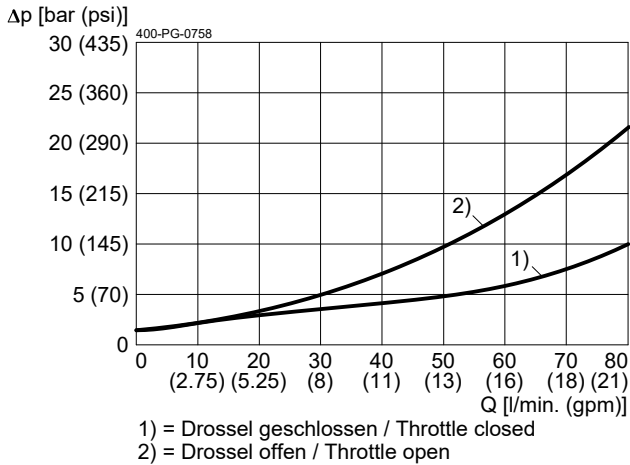

$p = f(Q)$  Pressure-flow rate

Adjustment, fine opening

Measured via check valve

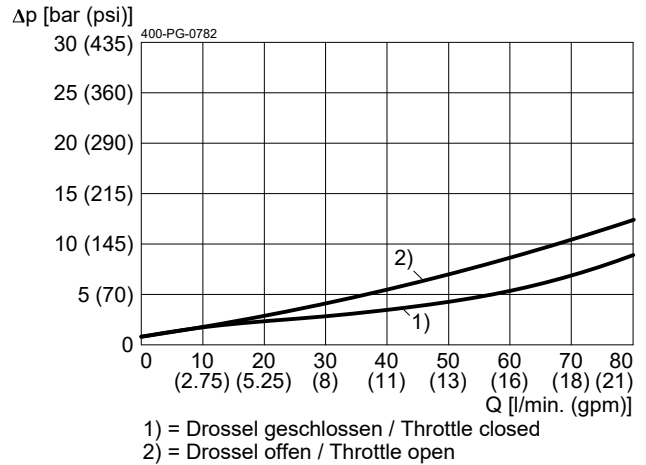

$Q = f(I:\Delta p)$  Flow rate adjustment

Adjustment, normal opening

Measured with supply channel 1 and 2 = Ø7mm

At constant throttle settings

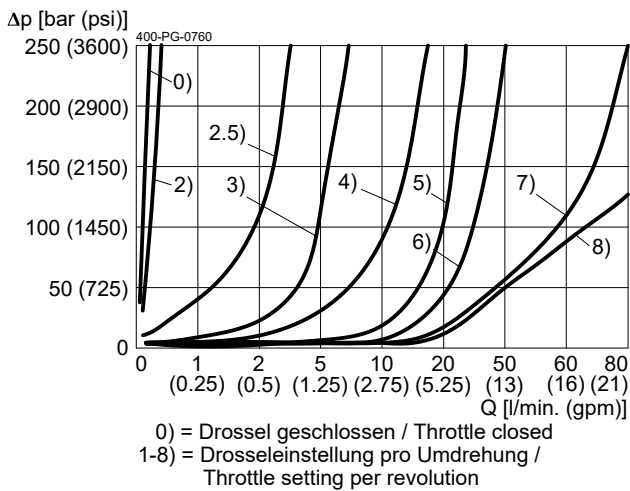

$Q = f(I:\Delta p)$  Flow rate adjustment

Adjustment, fine opening

Measured with supply channel 1 and 2 = Ø7mm

At constant throttle settings

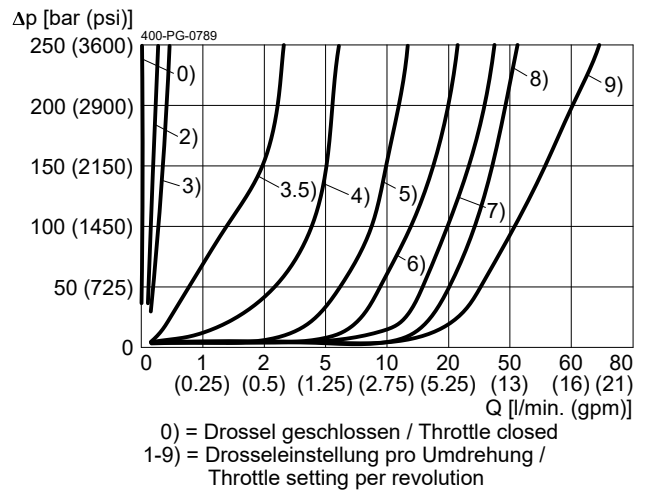

## Dimensions and sectional view

**Beispiel für die Masseinheit:  
Exampel for the dimensional units:**

0.79 = 0.79 mm millimeter  
(.031) = 0.031" inch

Version "S": Einstellschraube mit Innensechskant (Standard)  
Version "S": adjustment screw with internal hexagon (standard)

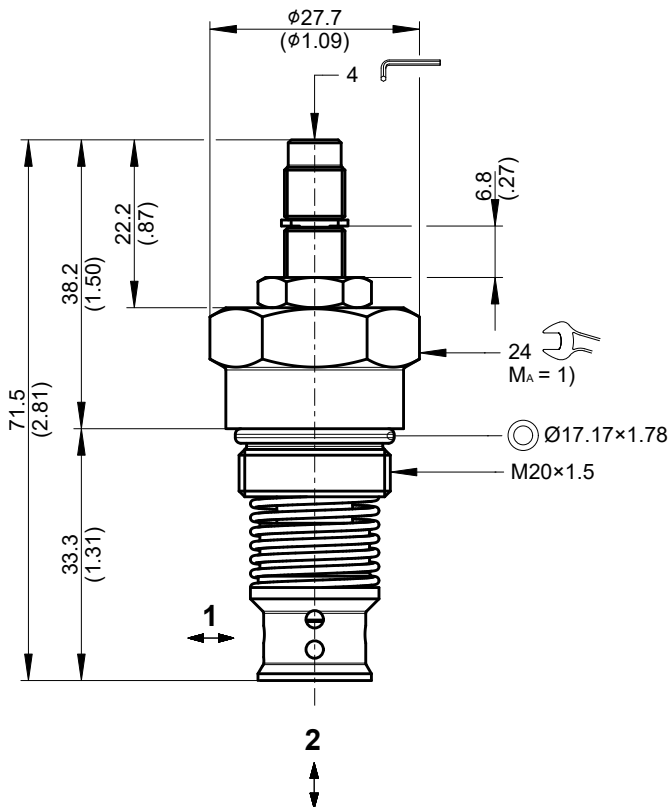

Version "H": Einstellschraube mit Handrad  
Version "H": adjustment screw with handknob

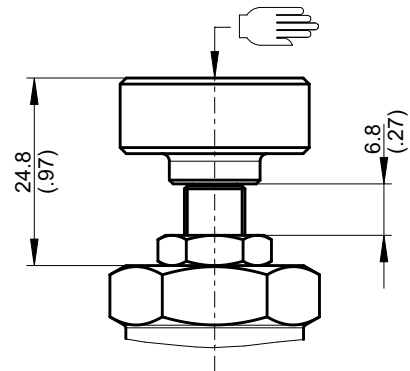

## Installation information



### ATTENTION!

Only qualified personnel with mechanical skills may carry out any maintenance work. Generally, the only work that should ever be undertaken is to check, and possibly replace, the seals. When changing seals, oil or grease the new seals thoroughly before fitting them.



### IMPORTANT!

1) When fitting the screw-in cartridge valve, use the specified tightening torque. The value can be found in the chapter "Technical data".



### NOTE!

The seals are not available individually. The seal kit order number can be found in the chapter "Technical data".

## Ordering code

Ex. **M D R 2 - 6 F - 0.7 - S - N A 1**

M	=	flow-regulating valve	
D	=	direct acting	
R	=	check valve function	
2	=	2-way/2-position function	
6	=	nominal size 6	
F	=	cavity type DF	
0.7	=	Check valve opening pressure 0.7 bar / 10 psi	<b>(standard)</b>
0.1	=	Check valve opening pressure 0.1 bar / 1.45 psi	
S	=	adjustment screw with internal hexagon	<b>(standard)</b>
H	=	adjustment screw with handknob	
(blank)	=	adjustment, normal opening	<b>(standard)</b>
F	=	adjustment, fine opening	
N	=	NBR (nitril-butadien-rubber / BUNA) seals	<b>(standard)</b>
V	=	FKM (fluorocarbon rubber / VITON) seals (special seals on request)	
A ... Q	=	standard model according to valid data sheet	
Z ... R	=	special model (on request)	
1 ... 9	=	technical design no. (omit by ordering)	

## Related data sheets

Reference	Description
<a href="#">400-P-040011</a>	Form tools
<a href="#">400-P-060131</a>	Cavity DF

[info.ch@bucherhydraulics.com](mailto:info.ch@bucherhydraulics.com)

[www.bucherhydraulics.com](http://www.bucherhydraulics.com)

© 2024 by Bucher Hydraulics AG Frutigen, 3714 Frutigen, Switzerland

All rights reserved.

Data is provided for the purpose of product description only, and must not be construed as warranted characteristics in the legal sense. The information does not relieve users from the duty of conducting their own evaluations and tests. Because the products are subject to continual improvement, we reserve the right to amend the product specifications contained in this catalogue.